

TOTE BAG

INSTRUCTIONS

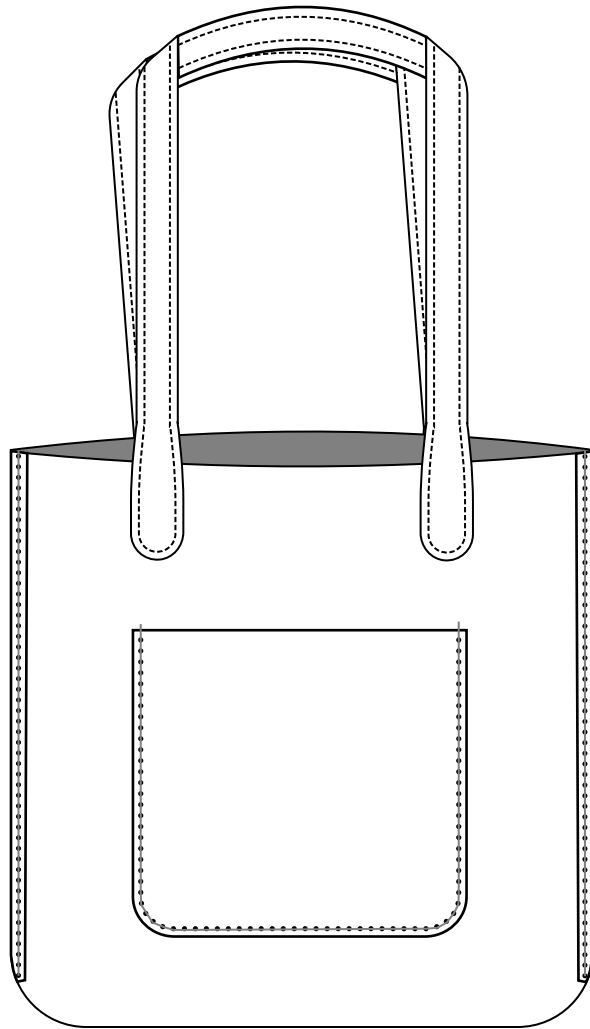

BUCKLEGUY

LEATHERCRAFT SUPPLY

STITCHING AND BURNISHING SUPPLIES

+NEEDLES

+THREAD(S):

- A. LARGE POCKET 80"
- B. FRONT AND BACK PANELS (x2) 53"
- C. INNER POCKET (FRONT TO BACK) 55"
- D. INNER POCKET TO BACK PANEL 13"
- E. BOTTOM PANEL (x2) 61"
- F. HANDLES (x4) 100"

+CANVAS

+SANDPAPER

+BEESWAX

LEATHER PIECES

- 1. FRONT PANEL
- 2. BACK PANEL
- 3. BOTTOM PANEL
- 4. LARGE POCKET
- 5. INNER BACK POCKET
- 6. INNER FRONT POCKET
- 7. HANDLES

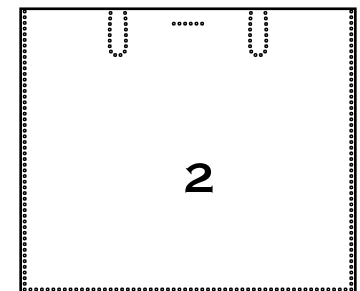
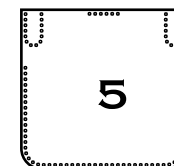
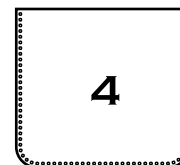
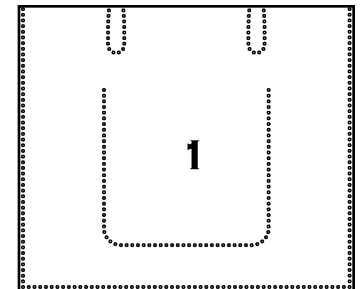
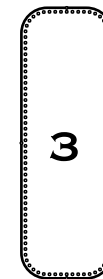

7





YOU SHOULD KNOW



PAPER BINDER CLIPS ARE PERFECT FOR HOLDING LAYERS OF LEATHER TOGETHER WHILE YOU STITCH. THEY SERVE THE PURPOSE OF SEWING PINS.

ALL STITCHING START POINTS ARE MARKED WITH A STAR.



FLESH VS. GRAIN COLORATION

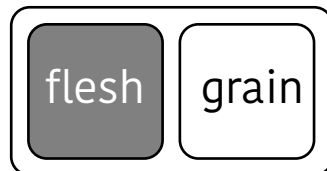

STEP 1: (Optional) Burnish everywhere marked by the grey lines below:

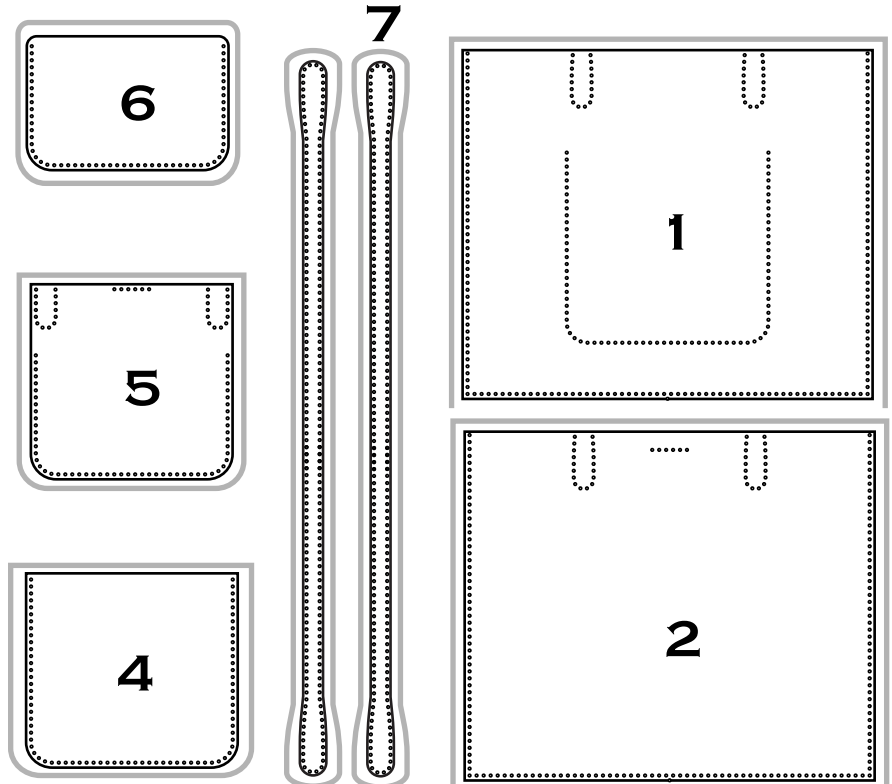

STEP 2: Saddle stitch the large pocket (4) onto the front panel (1) flesh side to grain side. Prepare your needles. Line up the large pocket (4) onto the front panel (1) so that there is one hole above the left side seam and one hole above the right side seam. Starting on the left side, thread the needle into the first hole of the front panel (1). Begin to saddle stitch, attaching the large pocket (4) onto the front panel (1) on your second stitch. Continue to saddle stitch the large pocket (4) onto the front panel (1), going all the way around the large pocket (4). Backstitch and pull both needles through to the flesh side of the front panel (1). Snip and carefully burn threads.

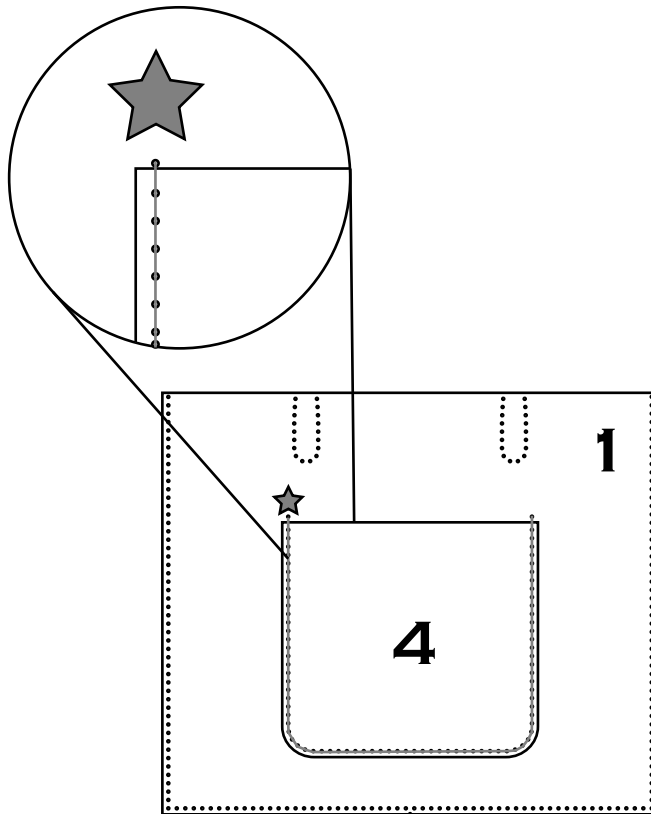

STEP 3: The sides are attached using an overlap seam. Saddle stitch the left side of the front panel (1) onto the right side of the back panel (2) flesh side to grain side. Prepare your needles. Lay the left side seam of the front panel (1) on top of the right side seam of the back panel (2) flesh side to grain side. Starting in the first hole at the top of the two panels, thread the needle through the two panels. Wrap each thread over the top edge of the panels, and then back through the first hole where you started. (See illustration below) Continue to saddle stitch all the way down the seam. When you get to the bottom/last hole, backstitch, snip, and burn threads.

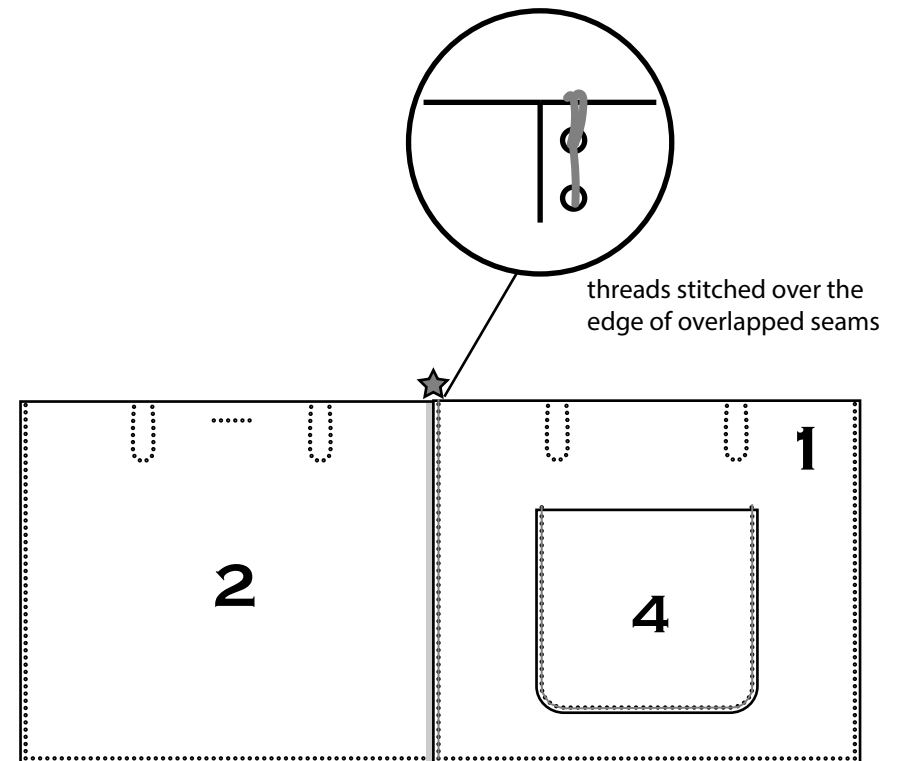

overlapped seams

STEP 4: Saddle stitch the left side of the back panel (2) onto the right side of the front panel (1) flesh side to grain side. The flesh side of the back panel (2) should be facing you and your tote bag should be inside out at this point. Prepare your needles. Lay the right side seam of the front panel (1) below the left side seam of the back panel (2) grain side to flesh side. Starting in the first hole at the top of the two panels, thread the needle through the two panels. Wrap each thread over the top edge of the panels, and then back through the first hole where you started. Continue to saddle stitch all the way down the seam. When you get to the bottom/last hole, backstitch, snip, and burn threads.

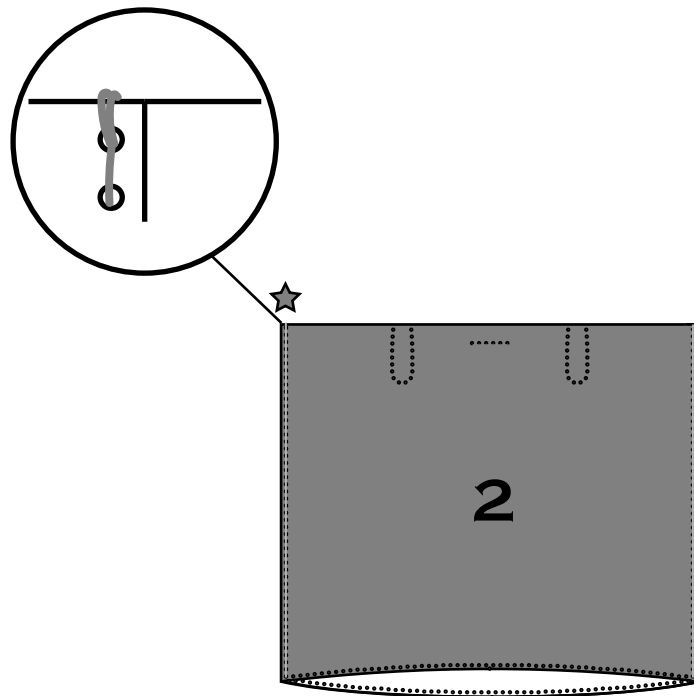

STEP 5: Saddle stitch the bottom panel (3) onto the base of the front panel (1) and back panel (2) grain side to grain side. Binder clips are helpful at this point. Prepare your needles. Start the thread by bringing a needle through the last hole of the left side seam where you already have stitches, and then continue the needle through the hole that lines up with the small “notch” on the short side of the bottom panel (3). Saddle stitch the bottom panel (3) onto the front panel (1) until you reach the second notch on the bottom panel (3) and the right side seam of the front (1) and back panel (2). Back stitch, snip and carefully burn threads. Prepare your needles to stitch on the second half of the bottom panel (3) making sure the second notch on the opposite side of the bottom panel (3) lines up with the right side seam of the front (1) and back panel (2). Saddle stitch the entire bottom panel (3) onto the back panel (2). When you reach the left side seam where you started step 6, backstitch, snip, and carefully burn threads.

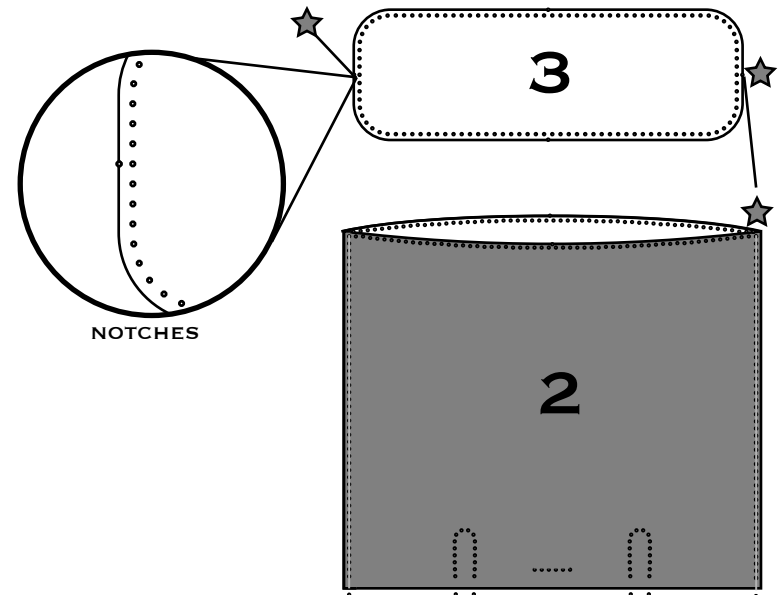

NOTE

THE BOTTOM EDGE OF FRONT PANEL (1) AND BACK PANEL (2) AND THE OUTER EDGE OF BOTTOM PANEL (3) HAVE NOTCHES THAT LINE UP TO THE SIDE SEAMS AND CENTER POINTS.

STEP 6: Ready for a quick workout? Flip the tote bag right side out. Remove any personal jewelry to avoid scratching. Start by rolling down the top of the panels, slowly working the bottom panel (3) through the stitched front panel (1) and back panel (2).

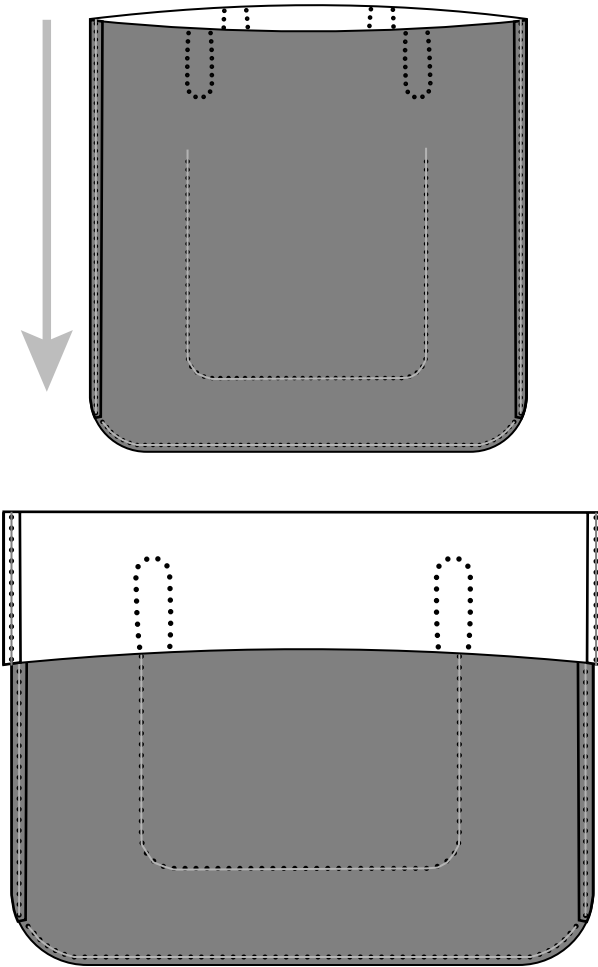

BUCKLEGUY

LEATHERCRAFT SUPPLY

Rotate the bag and push the bottom of it down.

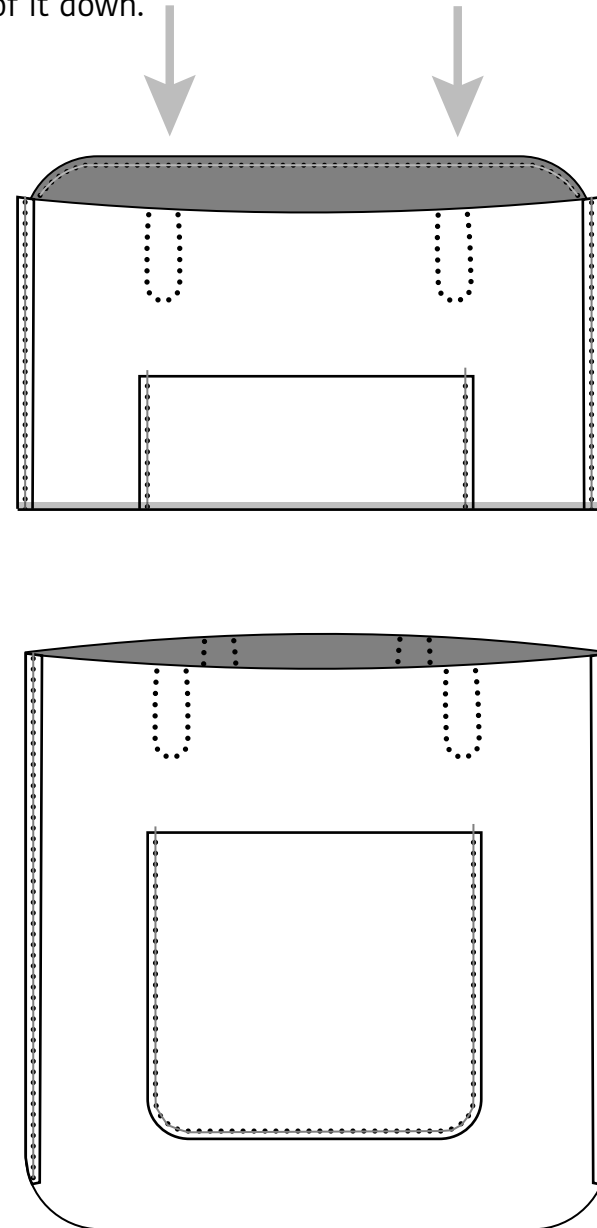

STEP 7: Saddle stitch the inner front pocket (6) onto the inner back pocket (5) grain side to flesh side. Prepare your needles. Line up the inner front pocket (6) onto the inner back pocket (5). Start the thread on the left side of the two pieces, in the first hole and saddle stitch all the way around the pocket. When you get to the last hole on the right side, backstitch and pull both needles through to the flesh side of the inner back pocket (5). Snip and carefully burn threads.

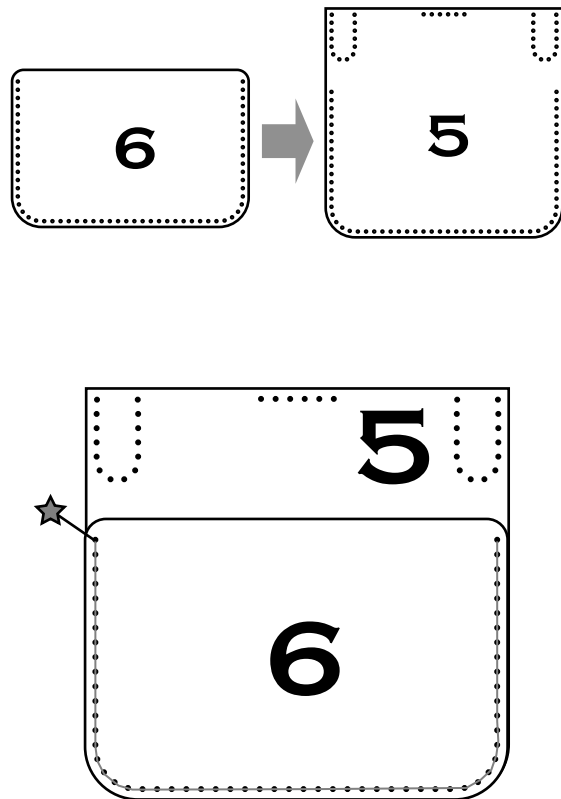

STEP 8: After the shell is flipped right side out, saddle stitch the 6 hole seam of the inner back pocket (5) onto the back panel (2) flesh side to flesh side. This means it is getting stitched on the INSIDE of the bag. Prepare your needles. Starting in the left hole, saddle stitch to the last hole. Backstitch twice and pull both needles through to the grain side of the inner back pocket (5). Carefully snip and burn threads.

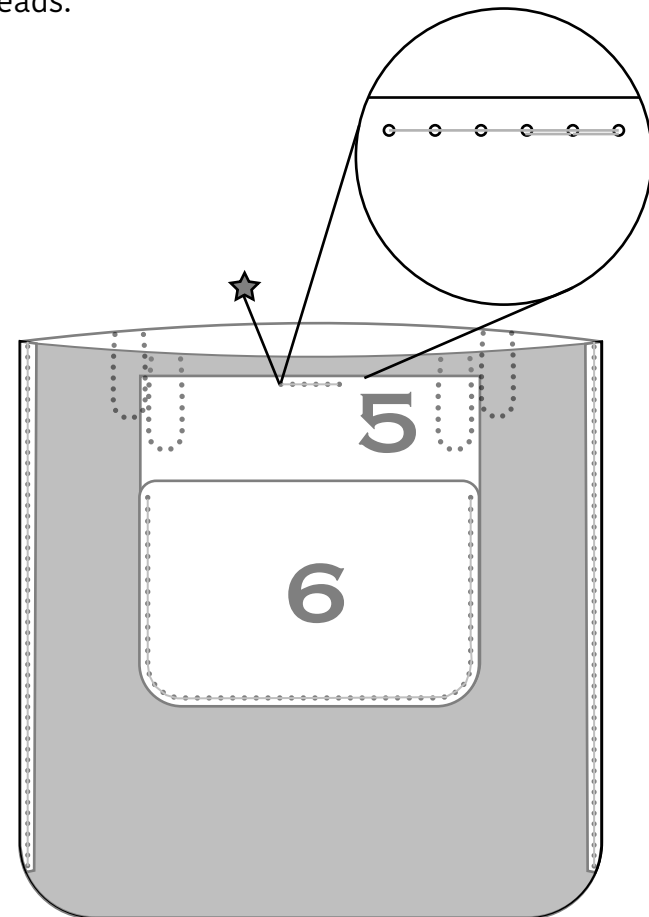

STEP 9: Saddle stitch the handles (7). Lay one handle out in front of you horizontally. Notice the protrusion at each end of the handle (7). This is where the handle (7) will attach to the front (1) and back (2) panels. Start on the left end of the handle (7), and bring your needle two holes into the protrusion, toward the rounded end of the handle (7). Begin to saddle stitch along the top of the handle (7). When you reach the protrusion on the right end of the handle (7), continue to saddle stitch through two more holes. Pull the needles off of your threads and leave the threads hanging. Prepare another piece of thread to saddle stitch along the bottom seam of the same handle (7), this time starting at the right end of the handle and ending on the left end of the handle. Begin your needle on the right side bottom seam, directly across from when your top row of stitching ended, two holes into the protrusion. Saddle stitch all the way along the bottom seam, stopping when you reach the stitching hole directly across from where your stitching began on the top seam of the handle (7). Pull the needles off the threads and leave the threads hanging. You will have threads hanging on either side of the handle (7). Repeat for the second handle (7).

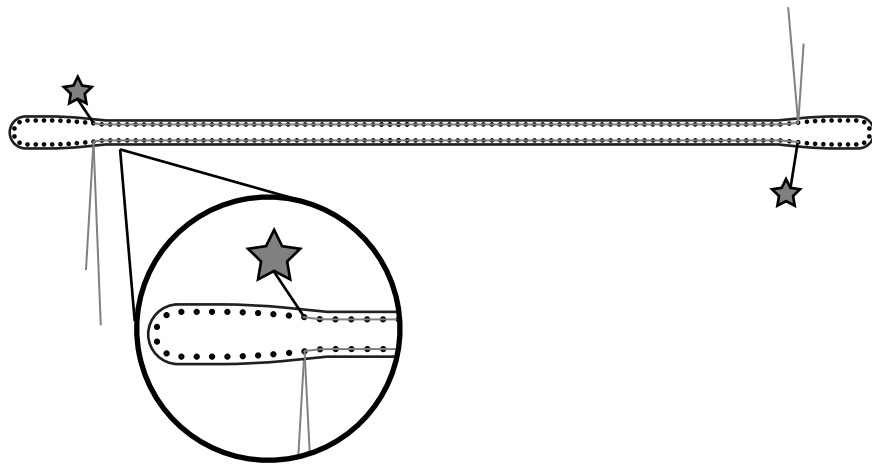

BUCKLEGUY

LEATHERCRAFT SUPPLY

STEP 10: Stitch the handles (7) onto the front panel (1) and back panel (2) grain side to flesh side using the hanging thread slack from the handle (7) seams. Rethread the hanging threads onto your needles. Begin by lining up the left end of the handle (7) onto the left handle seams on the front panel (1) flesh side to grain side. Continue your previously started saddle stitch, this time pulling the needles and thread through to attach the handle (7) onto the left side of the front panel (1). Back stitch for extra strength. Continue to saddle stitch around the protrusion. When you reach the other side of the protrusion, back stitch and pull both needles through to the flesh side of the handle (7). Snip threads and carefully burn. Align the right side of the same handle (7) onto the right handle seam of the front panel (1). Saddle stitch the right side of the handle (7) onto the right handle seam of the front panel (1) the same way. Repeat this step for the second handle (7) onto the back panel (2). Note- While stitching on the second handle (7) make sure to bring your needle through the handle (7), the back panel (2), and the inner back pocket (5).

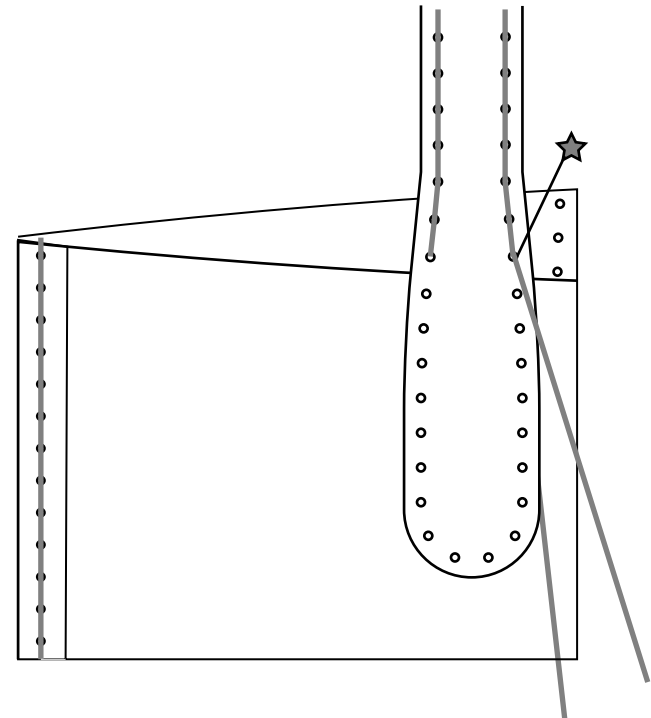

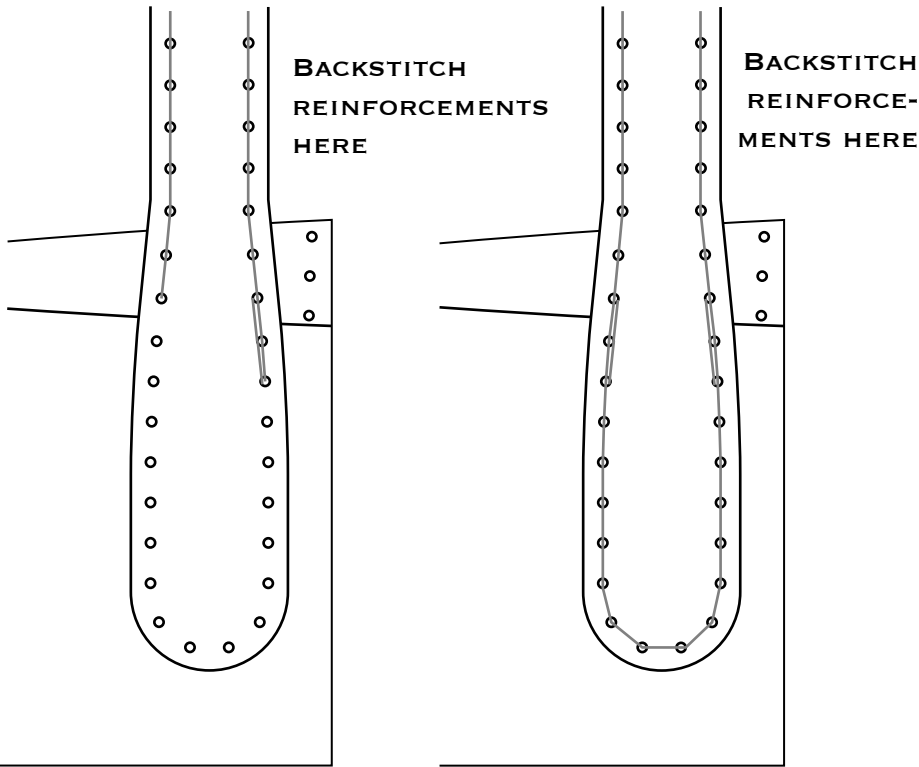

orientation when stitching on the handle (7) when you get to the inner back pocket (5)

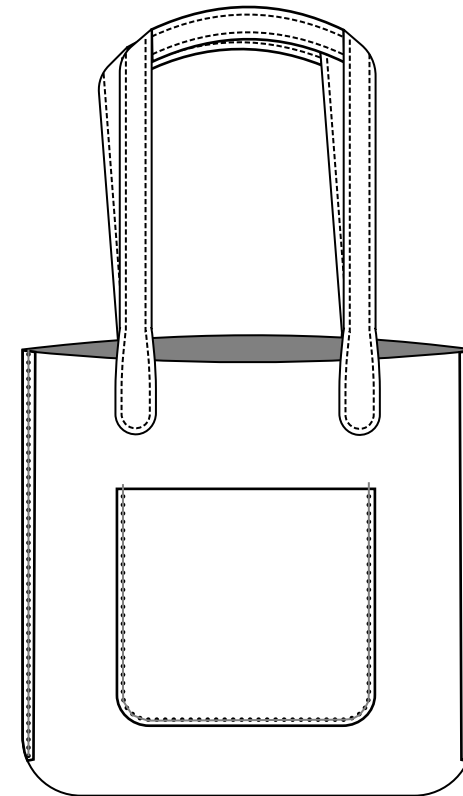
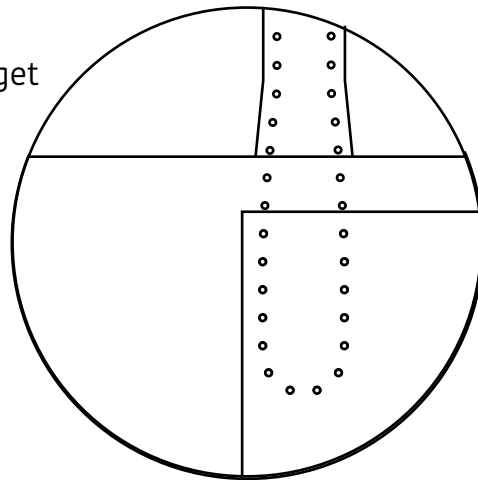

THANKS FROM ALL OF US AT BUCKLEGUY!

SHARE YOUR PROJECTS WITH US ON
SOCIAL MEDIA

BY USING THE HASHTAG #BGKITS



@BUCKLEGUYCOM



@BUCKLEGUY



@BUCKLEGUY



@BUCKLEGUY.COM