

# MAT SCOOPS

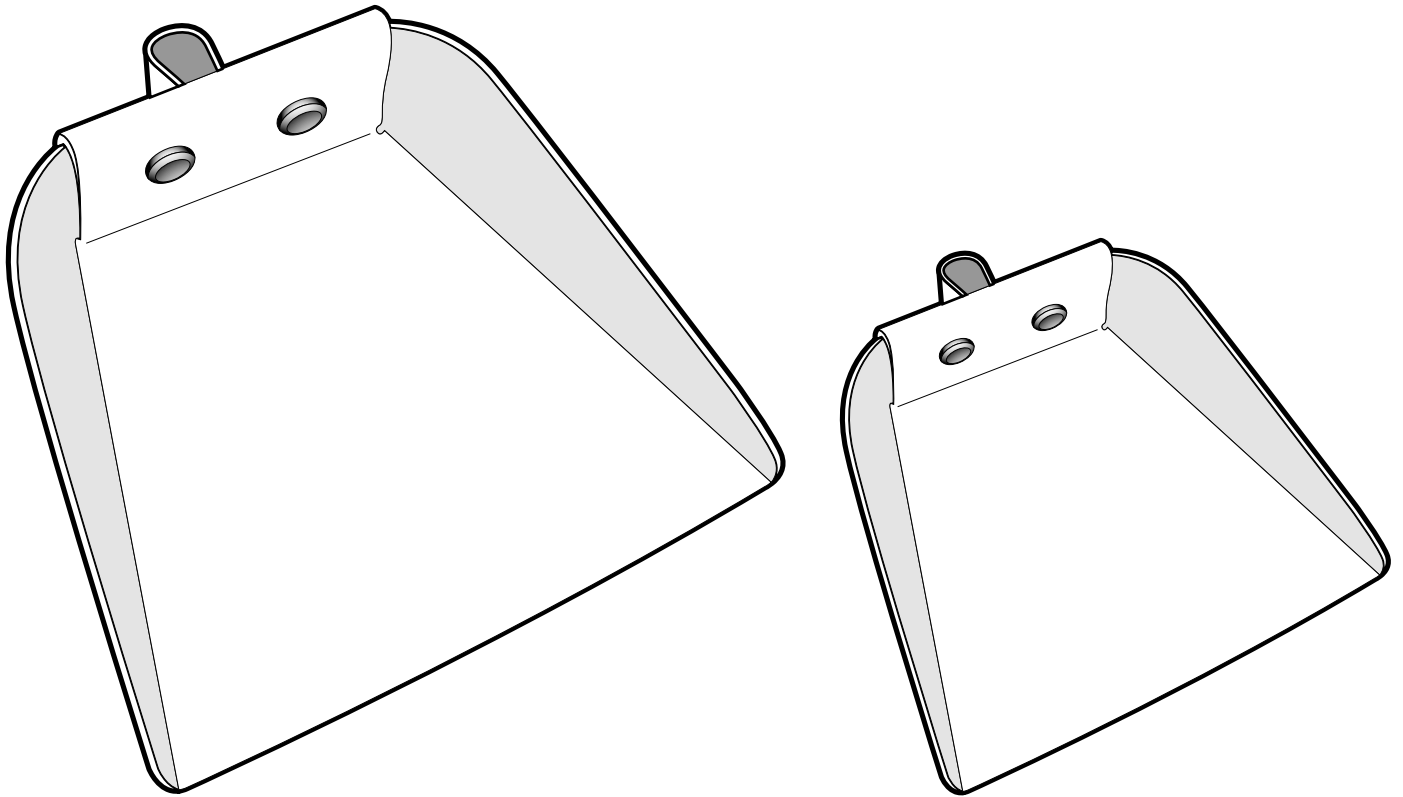

&

# BUCKLEGUY

LEATHERCRAFT SUPPLY

## ABOUT BUCKLEGUY

FOUNDED IN 1945, FOUR GENERATIONS OF OUR FAMILY HAVE SUPPORTED CLIENTS WITHIN THE MARKETS OF LEATHER GOODS AND ACCESSORIES. THROUGH THE GENERATIONS WE HAVE DISTRIBUTED LEATHER, TANNING MACHINERY, TOOLS, AND FOR THE PAST 40 YEARS MANUFACTURED SOLID BRASS HARDWARE FOR HIGH-END ACCESSORY BRANDS. SINCE 2000 WE HAVE OWNED AND OPERATED OUR OWN HARDWARE MANUFACTURING FACILITY.

IN 2010, WE STARTED BUCKLEGUY.COM AS A WHOLESALE SUPPLY WEBSITE FOR LEATHER CRAFTERS, HOBBYISTS, AND MANUFACTURERS IN SEARCH OF BETTER QUALITY PRODUCTS TYPICALLY UNAVAILABLE AT SMALL QUANTITIES. SINCE BUCKLEGUY'S INCEPTION WE HAVE SEEN A SURGE OF QUALITY DEMANDS FROM AMERICAN-MADE AND GLOBAL MAKERS THAT HAVE BEEN SEEKING SUPPLIES THAT ELEVATE THEIR OWN PRODUCTS. OVER TIME WE HAVE EXPANDED OUTSIDE OF HARDWARE AND PARTNERED WITH SOME OF THE BEST SUPPLY MANUFACTURERS IN THE WORLD IN THE MARKETS OF LEATHERS, ZIPPERS, TOOLS, THREADS, AND MORE.

ALL THE MATERIALS AND COMPONENTS THAT GO INTO OUR KITS COME FROM US AND OUR FAMILY OF VENDORS. WE ALSO DESIGN MANY OF THE KITS IN HOUSE. OUR MISSION IS TO MAKE THE FINEST LEATHER KITS WITH THE BEST MATERIALS THE MARKET HAS TO OFFER! WE HOPE YOU LOVE THEM!

---

THANKS FROM ALL OF US AT BUCKLEGUY!

PLEASE SHARE YOUR PROJECTS WITH US ON SOCIAL MEDIA

---



@BUCKLEGUYCOM



@BUCKLEGUY



@BUCKLEGUY



@BUCKLEGUY.COM

# BUCKLEGUY

LEATHERCRAFT SUPPLY

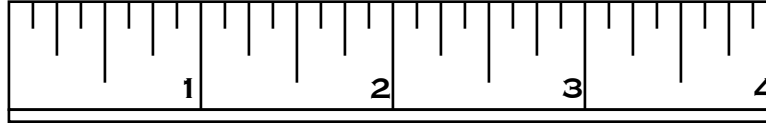

**PRINT THIS PAGE FIRST** AND MEASURE THIS RULER AGAINST YOUR OWN TO CHECK THAT IT IS PRINTING AT 100% SCALE.

### DIGITAL PDF PRINTING INSTRUCTIONS

**THE PATTERN IS DESIGNED TO BE PRINTABLE. WE TOOK INTO CONSIDERATION THE STANDARD PRINTER MARGINS FOR LETTER SIZED PAPER.**

**SELECT “US LETTER” (8.5” X 11”) UNDER PAPER SIZE. MAKE SURE PORTRAIT MODE IS SELECTED.**

**BE SURE TO CLICK “SCALE: 100%” AS SEEN HERE TO ENSURE THAT THE PAGE IS GOING TO PRINT TO SCALE.**

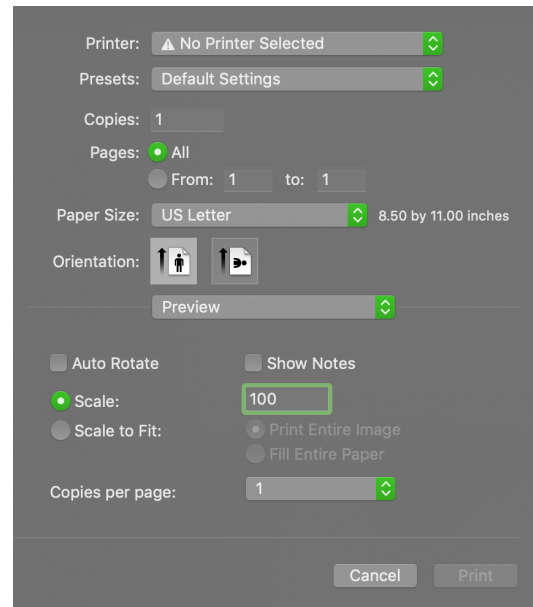

# BUCKLEGUY

LEATHERCRAFT SUPPLY

## Edge Finishing

**Sanding:** This is done before burnishing when you have multiple layers of leather stitched together. Use the sandpaper to lightly sand the sides of the leather until the multiple layers of leather are flush. Hold the sandpaper at an angle on the edge of leather to round any corners. This is not necessary on single layers.

**Burnishing** is the process of polishing the edges of leather. This is an aesthetic choice and is optional. The edges will burnish naturally on their own over time!

**To Burnish:** First use water to lightly dampen the edge. Wait ten seconds for it to seep in. Once wet, use the canvas cloth or a wood edge slicker to rub back and forth along edges until a light shine is achieved. When you're burnishing a single layer of leather, make sure that you are gentle. After this, rub beeswax along the edge and repeat the process of burnishing with the cloth or the wood edge slicker. This process can be repeated to darken or smooth further.

Note: If during the burnishing process edges peen over, sand the edge again at a 45° angle and re-burnish. If you have an edge beveler, you can take off the corners and round off the edges before repeating the burnish process.

BELOW ARE THE PATTERN PIECES INCLUDED IN THIS KIT.  
THERE ARE 2 PATTERN PIECES TOTAL.

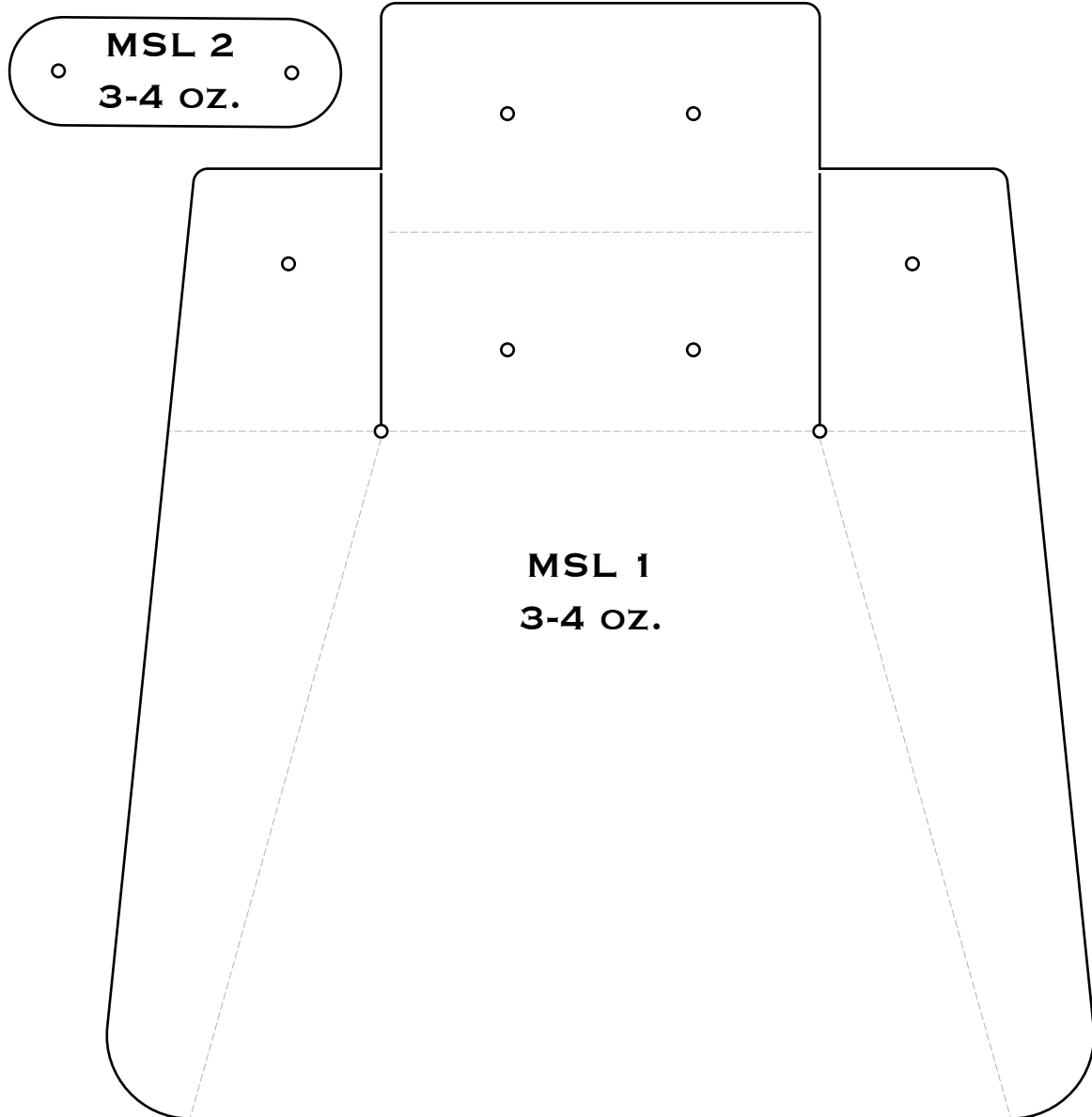

**BUCKLEGUY**

LEATHERCRAFT SUPPLY

**3-4OZ. LEATHER PIECES:**

- 1. SCOOP**
- 2. STRAP**

**BURNISHING SUPPLIES:**

- +CANVAS**
- +SANDPAPER**
- +BEESWAX**

**HARDWARE**

- +2, MINI CHICAGO SCREWS: (BG SKU:CS6605-OD)**

**TOOLS REQUIRED:**

- FLAT SCREWDRIVER**

**STEP 1:** (Optional) Burnish edges marked by grey lines below:

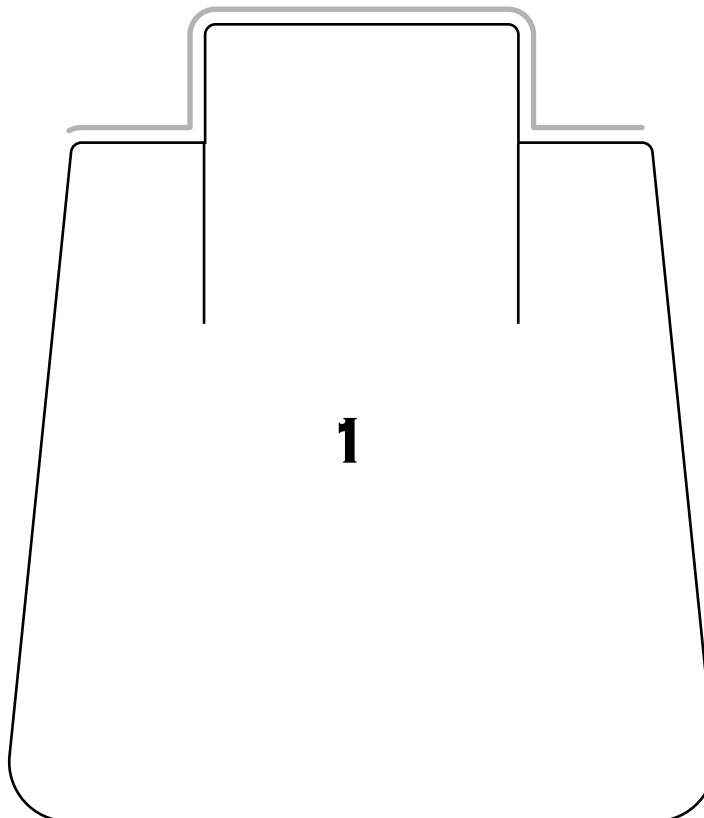
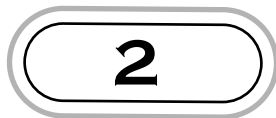

**BUCKLEGUY**

**LEATHERCRAFT SUPPLY**

**STEP 2:** Fold the Scoop (1) tabs as indicated on one side. Insert tube side of a Chicago screw through three layers from inside scoop. Align one Strap (2) hole with Chicago screw and screw threaded post side of screw into tube side. Repeat for other side.

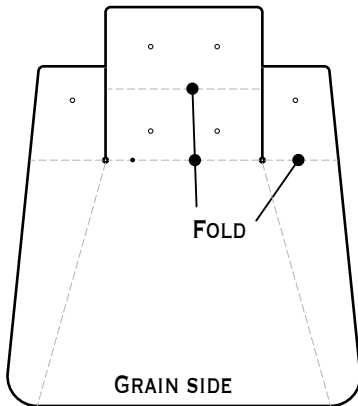

2.1

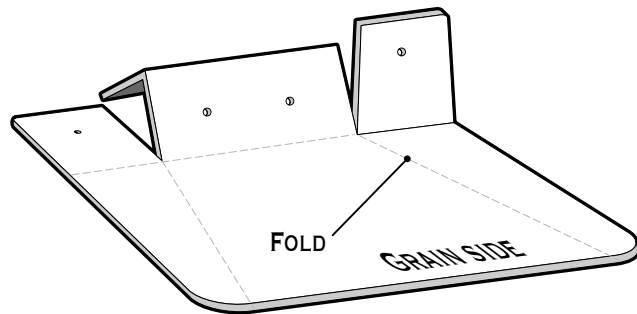

2.2

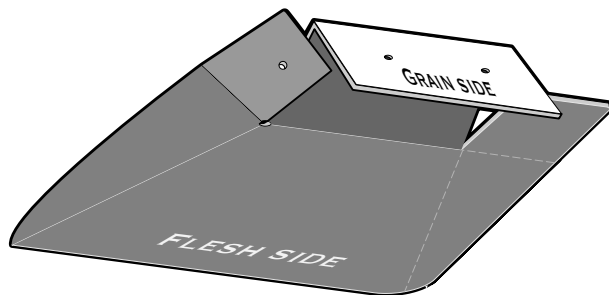

2.3

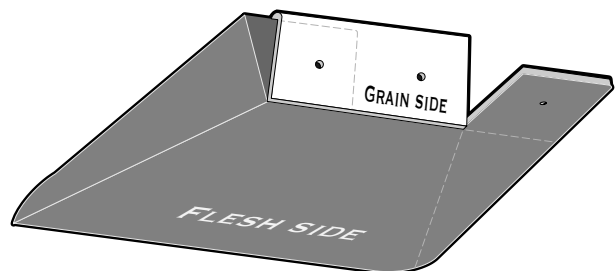

2.4

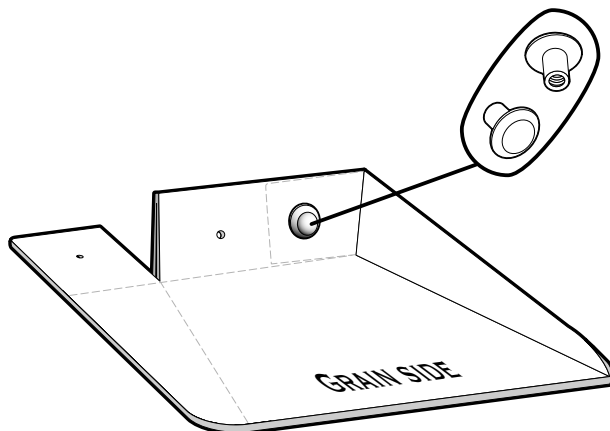

2.5

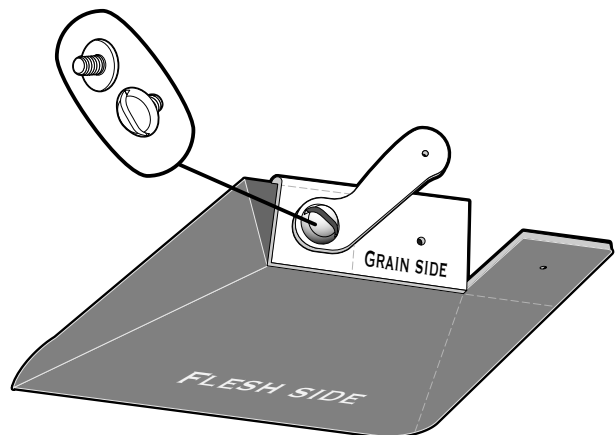

2.6



**BUCKLEGUY**

**LEATHERCRAFT SUPPLY**

**STEP 3:** Scoop should look like this after step 2. Burnishing and finishing edges indicated by grey line below is optional.

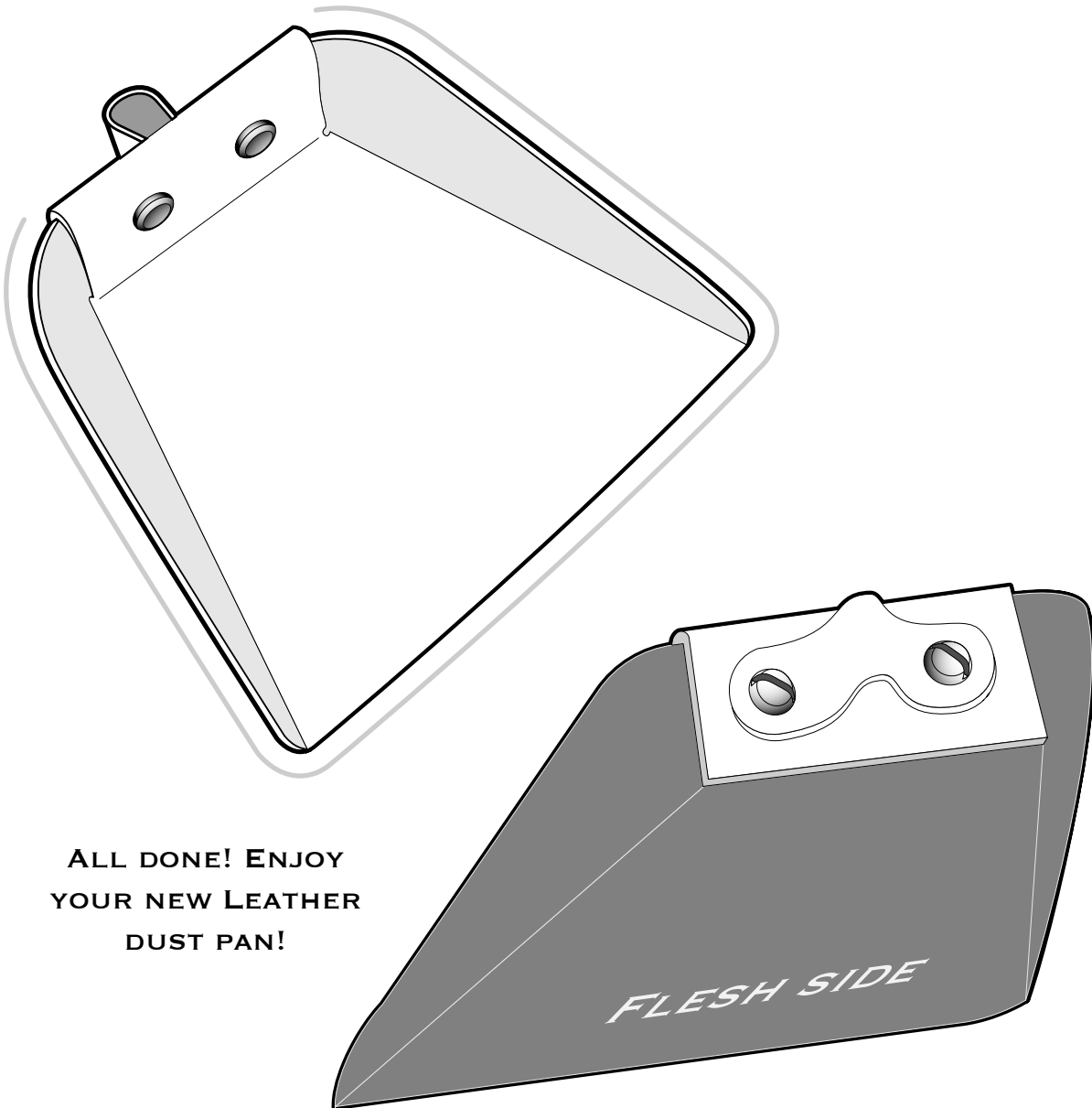

**ALL DONE! ENJOY  
YOUR NEW LEATHER  
DUST PAN!**



**BUCKLEGUY**

**LEATHERCRAFT SUPPLY**